

Cup-shaped vacuum cups

Diameter 9 mm, with or without shaped support, rubber

MATERIAL

Vacuum cup in silicone rubber (VMQ).
Nickel-plated brass support.

STANDARD EXECUTIONS

- **VVH-09-S**: silicone rubber, without support.
- **VVH-09-T-S**: silicone rubber, with support.

FEATURES AND APPLICATIONS

They are used in various sectors including electronics for gripping of electrical components, food packaging and, in general, for handling products with very different technical characteristics in terms of size, materials (metal or plastic), form, and gripping surfaces (flat, slightly convex or concave).

See Technical Data for vacuum cups (on page -).



VVH-09-S

VVH-09-T-S

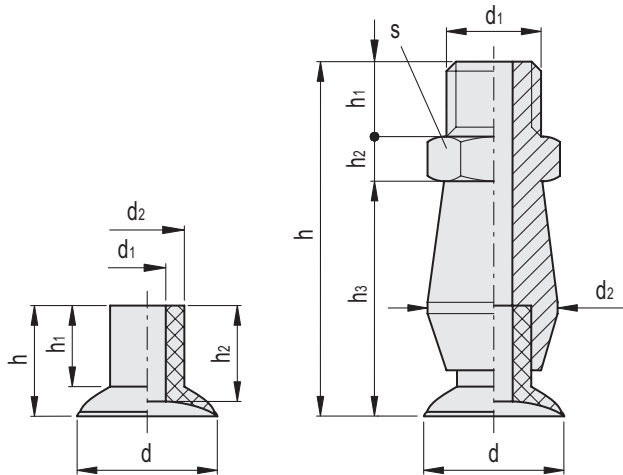

VVH-09-S

Code	Description	d	d1	d2	h	h1	h2	F* [Kg]	Volume # [mm3]	
VV.52030	VVH-09-S	9	2	5	7	5.5	6	0.15	56	1

VVH-09-T-S

Code	Description	d	d1	d2	h	h1	h2	h3	s	F* [Kg]	Volume # [mm3]	
VV.52031	VVH-09-M5-T-S	9	M5	7	20.5	5	3	12.5	7	0.15	56	4

* The force of the vacuum cups indicated in the table represents 1/3 of the value of the theoretical force calculated at a vacuum level of -75 KPa and a safety coefficient of 3.

Indicates the internal geometric volume of the vacuum cup and represents the volume to be added to the entire distribution circuit for the calculation of the evacuation time, especially if multiple vacuum cups are used.